

Includes Models:

11000, 11010, 11035,
11080, 11090, 11095



Read complete instructions
before using this Gun.

Part 1. Operation & Description

The DUALCO Hydraulic Grease Gun, model 11000, is a high-pressure tool that should be used with caution and according to these instructions.

IMPORTANT - This Gun is 10,000 psi rated. Do not exceed 10,000 psi.

The (numbers) shown herein refer to the Parts List on page 3 and in Brochure 363-898.

One end of the DUALCO 11000 Gun is the Fluid Bag Barrel (41) housing the Fluid Bag (42). The Hydraulic Fluid is contained within the fluid bag. The other end of the Gun is the Grease Barrel (47). The Barrels are separated by the Gun Body (1), which is equipped with a Check Valve (10), Plunger (7) and other components. During operation, action of the Handle (45) causes the Plunger (7) to move out of the Cylinder (2) with the hydraulic fluid following. As the Plunger (7) goes into the Cylinder (2) it forces the hydraulic fluid into the space behind the Piston Assembly (10810) located in the Grease Barrel (47). This Piston (26) pushes the material out through the Grease Barrel Cap (48). Numerous options are available for Grease Barrel Cap (48) attachments to transmit material to the desired pump, valve, or other equipment.

The Handle (45) has a side hole near the threaded end, which will fit over the pin in the Grease Barrel Cap (48). Using the Handle in this manner makes it a convenient tool to loosen and tighten the Cap (48). Only use the Handle (45) for loosening and tightening the Grease Barrel Cap (48). The Handle is marked with approximate 1-ounce graduations for measuring dispensed material. The Handle can be used for pushing the Piston (26) to bottom of Grease Barrel (47).

To ensure the DUALCO Hydraulic Grease Gun will perform and operate properly use after use, keep the gun out of the weather, clean, and maintained.

Part 2. Loading

Each new DUALCO Hydraulic Grease Gun is ready to use, following this procedure:

- A. Unscrew Grease Barrel Cap (48).
- B. Make sure Piston Assembly (10810) is at the bottom of Grease Barrel (47) firmly against Body (1).
- C. Load the Barrel (47) with material (Lubricant, Packing, Sealant, or Cleaner).
- D. Replace Grease Barrel Cap.
- E. Tighten Cap with Handle (45). (Using Handle for this purpose, see Part 3, Item 2B.)

Be sure to have the appropriate material transmission apparatus or hose assembly firmly attached to the Grease Barrel Cap (48) before Gun operation.

The DUALCO 11000 Gun will need reloading if there is a sudden increase in resistance while operating the Handle (45). This is an indication that the Piston Assembly (10810) has reached the Barrel Cap (48). Do not continue to pump Piston Assembly when it reaches the Barrel Cap (48). Use the following reloading procedure:

- A. Open By-Pass Valve (17) to relieve pressure. One turn of the valve is sufficient.
- B. Remove Grease Barrel Cap (48) with Handle (45) as previously described.
- C. Using Handle (45), push Piston to bottom of Grease Barrel (47) so it will be flush against Body (1).
- D. Close By-Pass Valve (17). Hand tight is sufficient.
- E. Using either bulk, prepackaged, or "J" size stick material, reload Grease Barrel (47).
- F. Replace Grease Barrel Cap (48) and tighten with Handle (45).
- G. Replace Handle (45) into Fulcrum Assembly (44) and the Gun is ready to operate.

To load from a cartridge, see Material Loader Instruction Sheet.

Distributed by:
Linc Energy Systems
www.LincEnergySystems.com

8404 Braniff
Houston, Texas 77061
713-644-1164 • FAX 713-644-7761
www.dualco-inc.com



Producing Professional Lubrication products since 1960. Products are made and assembled in the USA. 100% Repairable and Recyclable.



Part 2. Loading continued

IMPORTANT - Always make sure the Grease Barrel Cap (48) is firmly attached to the Grease Barrel (47) and be sure there is full thread engagement between these two parts before each Gun operation.

IMPORTANT - Some variations of the DUALCO 11000 Gun are equipped with a Latch Assembly (10830), which is to keep the Handle (45) in place when the Gun is not in use. The Gun must not be carried by the Handle (45), as this could cause the Plunger (7) to break. A Handle Strap (46) is available to secure the Handle (45) to the Grease Barrel (47).

An optional Handle Assembly, part 10995, is available; as is an optional Carrying Strap, part 10644.

Part 3. Maintenance

Any repair or service requiring disassembly of the DUALCO Hydraulic Grease Gun must be performed in a dirt-free environment by a qualified DUALCO technician with proper instructions. Dispose of used parts, lubricants, and fluids properly. It is wise to use environmentally safe cleaning solvents. Be sure to contact DUALCO if there is ever an operational problem, or if there are any questions.

Item 1. Hydraulic Fluid

The DUALCO 11000 Gun comes filled with DUALCO Hydraulic Fluid. Fluid should be added or replaced as necessary using only DUALCO Hydraulic Fluid. Do not contaminate or use any other fluid. Included as a standard accessory with each new DUALCO Hydraulic Grease Gun is a 4-ounce container of hydraulic fluid, which may be used for "topping" when necessary (See Part 3, Item 2, 2C.) The fluid is also available in other size containers up to 55-gallon drums. Fluid bag (42) capacity, excluding internal relief valve, is 12 ounces. Always wear proper personal protective gear when operating DUALCO equipment, such as safety glasses, gloves, hearing protection, etc.

Item 2. Refilling the DUALCO 11000 Gun with Hydraulic Fluid and purging the system of air.

2A The Gun should be refilled with DUALCO Hydraulic Fluid and purged of air only when the Piston Assembly (10810) is at the bottom of Grease Barrel (47), and flush against Body (1).

2B The procedure to move the Piston Assembly (10810) to the bottom of the Grease Barrel (46) is as follows:

Unscrew Handle (45) from Fulcrum Assembly (44). With a ¼" pipe nipple or other fitting screwed into the Grease Barrel Cap (48), remove the Cap with Handle (45) by placing the side hole of the Handle over the pin in Cap (48) and unscrew the Cap by applying leverage against the Grease Barrel fitting. Open By-Pass valve (17) one turn. Use Handle (45) to push Piston Assembly (10810) to bottom of Grease Barrel (47) so it will be flush against Body (1). Screw Handle (45) into Fulcrum Assembly (44).

2C Hold the Gun vertically, in a vise if available, with Fluid Bag (42) end up. Remove Fluid Bag Barrel Cap (40). Use Wrench, part 10895, to remove hex socket head cap screw on the end of Fluid Bag/Bleeder Assembly (42). Using a spouted can, slowly fill Bag (42) with DUALCO Hydraulic Fluid. Do not contaminate or use any other fluid. Allow 30 minutes (minimum) or the appropriate time for Gun to purge itself of air. Add fluid if necessary and replace cap screw, wrench tight. Replace Fluid Barrel Cap (40) all the way onto Fluid Bag Barrel (41) tightly with full thread engagement.



WARNING - Read Material Safety Data Sheet and DUALCO Hydraulic Fluid label before use.

Note - Contact DUALCO for other operation, repair, or rebuilding procedures.

IMPORTANT - Warranty will be voided if the By-Pass Valve (12), Cylinder (3), Plunger (8), Piston (41), Check Valve Screw (13) is removed from the Gun or if the Gun is disassembled or altered.



Producing Professional Lubrication products since 1960. Products are made and assembled in the USA. 100% Repairable and Recyclable.



Parts List

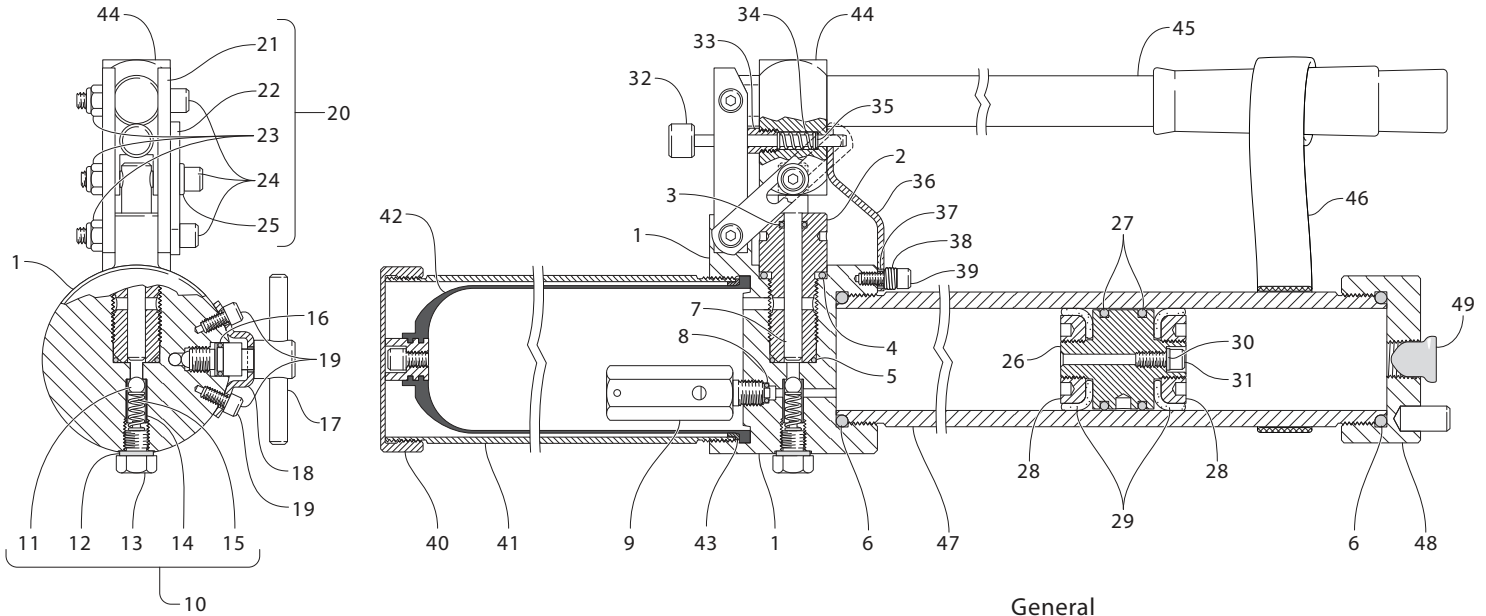

Body Assembly 10780

Key	Description	Part No.
1	Body	10782
2	Cylinder	★ ⊗ ⊕ ⊖ 10784
3	"O" Ring (Plunger)	★ ⊗ ※ * ⊕ ⊖ 10842
4	"O" Ring (Cylinder Upper)	★ ⊗ ※ * ⊕ ⊖ 10788
5	"O" Ring (Cylinder Lower)	★ ⊗ ※ * ⊕ ⊖ 10626
6	"O" Ring (Grease Barrel)	★ ⊗ ※ * 10811
7	Plunger	★ ⊗ ⊕ ⊖ 10785
8	"O" Ring (Internal Relief Valve)	★ ⊗ ※ * 10807
9	Internal Relief Valve (bulletin 99-190)	⊕ 10864
10	Check Valve Assembly	★ ⊗ 10790
11	Ball	* 10904
12	Gasket	* 10791
13	Check Valve Screw	10789
14	Filter Screen	* 10793
15	Spring	10792
16	"O" Ring (By-Pass Valve)	★ ⊗ ※ * 10048
17	By-Pass Valve	10795
18	Stem Retainer	10808
19	Cap Screw (2 Required)	10798

Link Assembly

20	Link Assembly	10781
21	Link (2 Required)	10777
22	Link Stop	11063

Link Assembly (continued)

Key	Description	Part No.
23	Lock Nut (3 Required)	10778
24	Stripper Bolt (3 Required)	10779
25	Washer	11064

Piston Assembly 10810

26	Piston	10815
27	"O" Ring (Piston) (2 Required)	★ ⊗ ※ * ◆ 10818
28	Washer Nut (2 Required)	10819
29	Leather Cup (2 Required)	★ ⊗ ※ ◆ 10821
30	Copper Gasket	★ ⊗ ※ ◆ 10817
31	Cap Screw	⊕ 10816

The Piston Assembly (part 10810) has an integral bleeder cap screw with a copper gasket. The bleeder assembly facilitates easy bleeding to assure there's no air entrapment.

Latch Assembly 10830

32	Stem & Knob Assembly	10835
33	Latch Screw	10833
34	Latch Spring, Internal	10837
35	Retaining Ring	10839
36	Latch Arm	10831
37	Latch Sleeve	10832
38	Latch Spring, External	10843
39	Cap Screw	10838

General

Key	Description	Part No.
40	Fluid Bag Barrel Cap	10823
41	Fluid Bag Barrel	10822
42	Fluid Bag / Bleeder Assembly	★ ⊗ 10820
43	Fluid Bag Seal Ring	⊕ 10828
44	Fulcrum Assembly	10772
45	Handle	10776
46	Handle Strap	11339
47	Grease Barrel	10961
48	Grease Barrel Cap	10813
49	Protective Plug (for Grease Barrel Cap)	10568
	Cylinder Spanner Wrench	⊕ 10893

DUALCO Hydraulic Fluid

1 - Pint Can	★ ⊗	10829
4 - oz. Can (Included with Hydraulic Grease Gun)	⊕	10895
1 - Quart Bottle		11019
1 - Gallon Can		10912

Repair & Maintenance Kits

★	Repair Kit, Minor	10295
⊕	Repair Kit, Major	10840
※	"O" Ring Kit	11055
*	Seal Kit	11065
⊕	Cylinder Repair Kit	11484
◆	Piston Seal Kit	10215
⊖	Cylinder • Plunger Assembly	11598

Kit Key



Producing Professional lubrication products since 1960. Products are made and assembled in the USA. 100% Repairable and Recyclable.



11345 Optional Check Valve Seating Tool Kit (For use on Hydraulic Grease Guns)

Parts & Instructions

1. Unscrew Check Valve Assembly (10) and remove all components from within the Check Valve cavity.

2. Make sure Check Valve cavity is clean and free of debris. To free any trapped particles from the Check Valve seat, clean with a soft bristle wire brush. Be careful not to scratch the Check Valve seat. Blow out any debris from the cavity with an air blow gun.

WARNING: When using an air blow gun be aware of flying debris.

Always wear eye protection.

3. Insert new Ball (11) into Check Valve cavity.

4. Screw in Tool Stem (50) hand tight.

5. Tighten Tool Stem (50) ¼ - ½ turn with Hex Wrench (51) 20-25 lb-ft torque.

6. Remove Tool Stem (50) from Check Valve cavity.

7. Leave new Ball (11) in Check Valve cavity. • Do Not reuse the old ball. (11)

8. Assemble other Check Valve Assembly components (10) into Body (1) of the Hydraulic Grease Gun.

Notes:

It is recommended that a new Check Valve Assembly (10) be installed into Gun after seating the new Ball (11)

The Check Valve seat does not always have to be resealed when repairing or rebuilding a gun. Depending on the amount of damage present on the seat, will determine if the Check Valve seat has to be resealed.

If the Check Valve cavity seat is too damaged, the Body (1) may have to be discarded and replaced.

• This tool (11345) is only necessary for use when repairing or rebuilding dualco hydraulic grease guns.

Parts List: 11345

11	Ball	10904
50	Seat Tool Stem	11348
51	90° 5/16" Hex Wrench	11347
52	Brush	11092

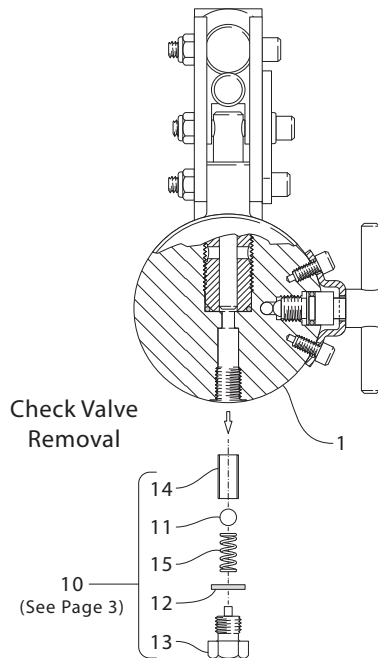

10 (See Page 3)

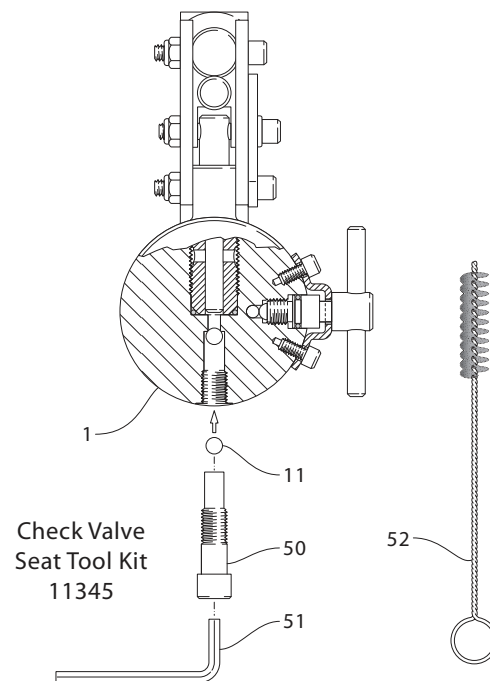

Producing Professional lubrication products since 1960. Products are made and assembled in the USA. 100% Repairable and Recyclable.

